

REVISIONS				
#	DATE	DESCRIPTION	DATE	BY
Y		REVISED PER ECO-16-005380	BAPR2016	DS SY

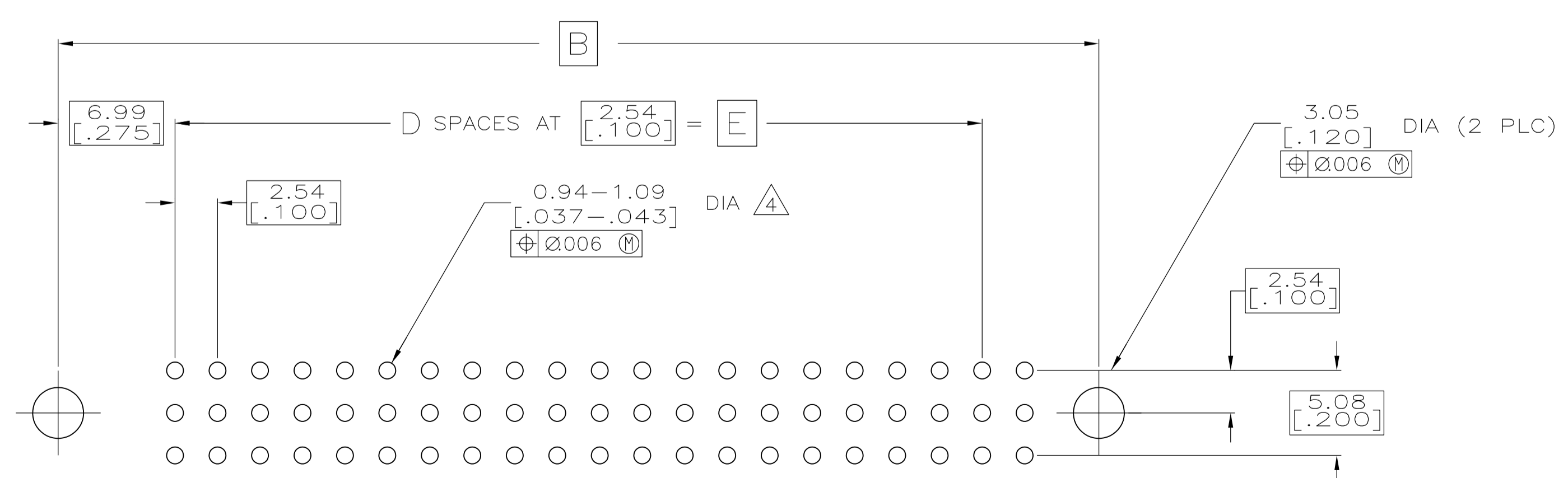
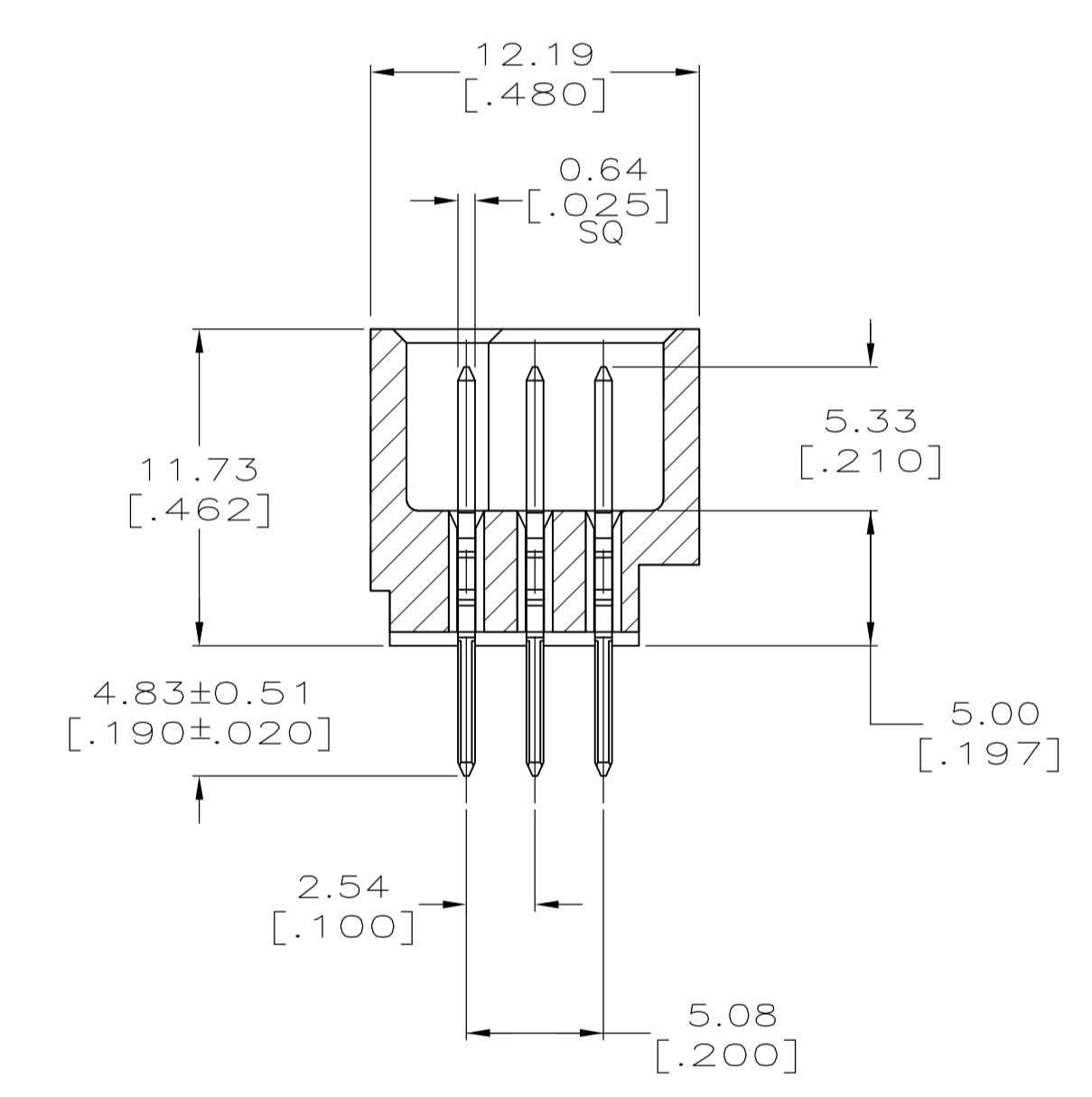
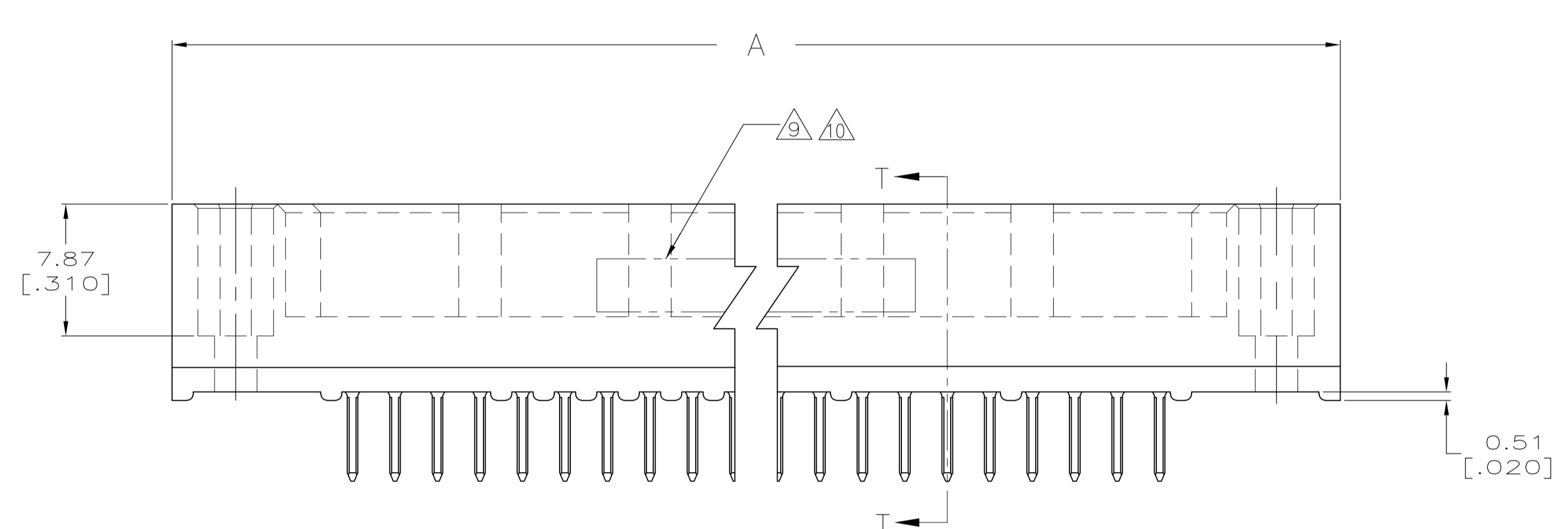
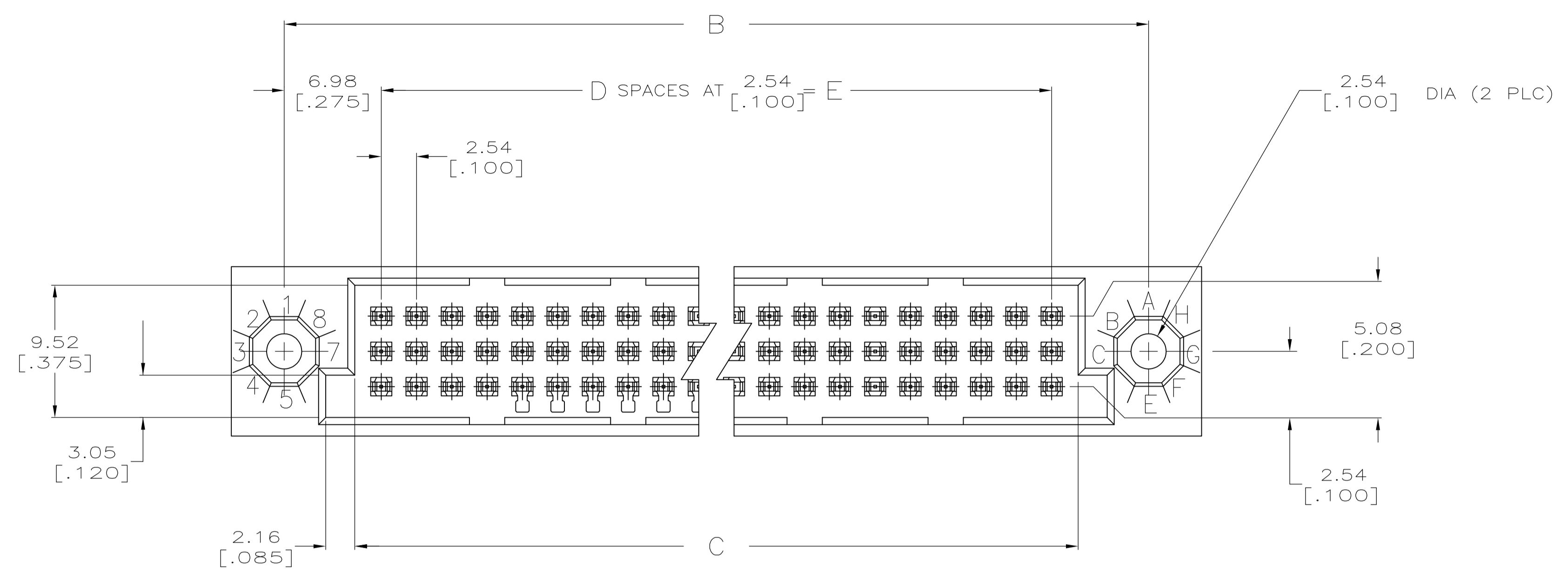

RECOMMENDED P.C. BOARD LAYOUT

THIS DRAWING IS A CONTROLLED DOCUMENT.		DWN: R.K. SEIFRIED 04/09/90	TE Connectivity	
DIMENSIONS: mm [INCHES]		CHK: G.SKIPPER 01/21/92	NAME: HDI, 3 ROW, PIN ASSEMBLY 4.83 [.190] LONG SOLDER PINS	
TOLERANCES UNLESS OTHERWISE SPECIFIED:		APVD: -	PRODUCT SPEC: -	
0 PLC ± - 1 PLC ± - 2 PLC ± - 3 PLC ± 0.13 [.005] 4 PLC ± - ANGLES ± -		APPLICATION SPEC: -	RESTRICTED TO: -	
MATERIAL:	FINISH:	WEIGHT: 0	SIZE: A1	CAGE CODE: 00779
CUSTOMER DRAWING		DRAWING NO: 532433	SCALE: 4:1	SHEET 1 OF 2

REVISIONS				
P	LTR	DESCRIPTION	DATE	APPV
-	-	SEE SHEET 1	-	-

- ① HOUSING MATERIAL: THERMOPLASTIC, COLOR-BLACK.
- ② CONTACT MATERIAL: PHOSPHOR BRONZE.
- ③ FINISH:
MATING AREA: MEETS THE PERFORMANCE REQUIREMENTS OF PRODUCT SPECIFICATION 108-9063; BASED ON TELCORDIA DR-1217-CORE APPLICATIONS IN UNCONTROLLED ENVIRONMENTS.
SOLDER TAILS AREA: TIN-LEAD PLATED.
- ④ SOLDER PIN POST RECOMMENDED P.C. BOARD HOLE SIZES ARE 0.94-1.09 [.037-.043]; RECOMMENDED PAD DIA IS 1.52 [.060].
- 5. DIMENSIONS IN BRACKETS ARE IN INCHES.
- ⑥ HOUSINGS WITH CENTER MOUNTING IS RECOMMENDED FOR ASSEMBLIES HAVING 75 CONTACTS PER ROW OR MORE.
- ⑦ PART NUMBER IS OBSOLETE.
- ⑧ NO CONTACT LUBRICANT
- ⑨ AMP, PART NUMBER, AND DATE CODE
- ⑩ OEFD0-983-9000-047, REV A, 00779 AND DATE CODE, ONLY FOR PART NUMBER 2-532433-3
- ⑪ PART NUMBER IS FOR ROCKWELL COLLINS.
- ⑫ FINISH:
CONTACT FINISH: .00127-.00254 [.000050-.000100] NICKEL UNDERPLATE ALL OVER; .000762 [.000030] GOLD PLATE IN CONTACT AREA, TIN-LEAD PLATED POSTS.

	60.96 [2.400]	24	64.77 [2.550]	74.93 [2.950]	82.55 [3.250]	75	2-532433-3
							2-532433-2
①	43.18 [1.700]	17	46.99 [1.850]	57.15 [2.250]	64.77 [2.550]	54	2-532433-1
②							2-532433-0
③	210.82 [8.300]	83	214.63 [8.450]	224.79 [8.850]	232.41 [9.150]	252	1-532433-9
④							1-532433-8
⑤							1-532433-7
⑥							1-532433-6
⑦							1-532433-5
⑧	213.36 [8.400]	84	217.17 [8.550]	227.33 [8.950]	234.95 [9.250]	255	1-532433-4
⑨	200.66 [7.900]	79	204.47 [8.050]	214.63 [8.450]	222.25 [8.750]	240	1-532433-3
⑩	187.96 [7.400]	74	191.77 [7.550]	201.93 [7.950]	209.55 [8.250]	225	1-532433-2
⑪	175.26 [6.900]	69	179.07 [7.050]	189.23 [7.450]	196.85 [7.750]	210	1-532433-1
⑫	162.56 [6.400]	64	166.37 [6.550]	176.53 [6.950]	184.15 [7.250]	195	1-532433-0
⑬	149.86 [5.900]	59	153.67 [6.050]	163.83 [6.450]	171.45 [6.750]	180	532433-9
⑭	137.16 [5.400]	54	140.97 [5.550]	151.13 [5.950]	158.75 [6.250]	165	532433-8
⑮	124.46 [4.900]	49	128.27 [5.050]	138.43 [5.450]	146.05 [5.750]	150	532433-7
⑯	111.76 [4.400]	44	115.57 [4.550]	125.73 [4.950]	133.35 [5.250]	135	532433-6
⑰	99.06 [3.900]	39	102.87 [4.050]	113.03 [4.450]	120.65 [4.750]	120	532433-5
⑱	86.36 [3.400]	34	90.17 [3.550]	100.33 [3.950]	107.95 [4.250]	105	532433-4
⑲	78.74 [3.100]	31	82.55 [3.250]	92.71 [3.650]	100.33 [3.950]	96	532433-3
⑳	73.66 [2.900]	29	77.47 [3.050]	87.63 [3.450]	95.25 [3.750]	90	532433-2
㉑	60.96 [2.400]	24	64.77 [2.550]	74.93 [2.950]	82.55 [3.250]	75	532433-1
	E	D	C	B	A	POSN	PART NUMBER

THIS DRAWING IS A CONTROLLED DOCUMENT.		DIN R.K. SEIFRIED 04/09/90 CHK G.SKIPPER 01/21/92		 TE Connectivity	
DIMENSIONS: mm [INCHES]		TOLERANCES UNLESS OTHERWISE SPECIFIED:		NAME HDI, 3 ROW, PIN ASSEMBLY, 4.83 [1.90] LONG SOLDER PINS	
0 PLC ± - 1 PLC ± - 2 PLC ± - 3 PLC ± 0.13 [.005] 4 PLC ± - ANGLES ± -		PRODUCT SPEC - APPLICATION SPEC -		SIZE A1	
MATERIAL ①②		FINISH ③④		WEIGHT 0	
CUSTOMER DRAWING		SCALE 4:1		SHEET 2 OF 2	